



ELIS PLZEŇ a.s.



## ULTRASONIC FLOW METER SONOELIS SE4041

## SONOELIS SE4041

Ultrasonic flow meter SONOELIS SE4041 is electronic device designed for measurement of fluid flow parameters with transit time method in a piping completely filled with the flowing fluid. The meter consists of a fluid flow sensor UC 3.0 and the evaluation electronic unit UP 2.20. These two parts are separated connected with two co-axial cables. Sensor UC 3.0 includes two ultrasonic transducers, that means it is a single-beam sensor. The application of this sensor extends the range of measured values, allows for shorter fluid-flow stabilization piping section at the meter input and output and generally increases the measurement accuracy.

In this separate version of the meter (with separated sensor and the associated electronic unit), the sensor is connected to the electronic unit by two co-axial cables of adequate length. This version is available in configuration named ECONOMIC, which is a basic version of a fluid flow-rate meter providing for conversion of the measured physical quantities to electric signals.

**This type of flow meter is designed primarily as a part of heat/cold meters.**

### METER SPECIFICATIONS

nominal diameter / size	DN32 to DN300 / 1 1/4" to 12"
nominal pressure [bar / psi]	40 / 600 (DN32 to DN80 / 1 1/4" to 3") and 16 / 150 (from DN100 / 5")
measurement accuracy EN 1434	2
temperature of measured liquid	0°C to 150°C / 32 °F to 302 °F
ambient temperature	5°C to 55°C / 41 °F to 151 °F
display unit	no display
power supply	110 to 250VAC, 50 to 60Hz (AC)
protection class (electronic unit)	IP 66
protection class (ultrasonic sensor)	IP 67
outputs (insulated)	pulse
optional accessories	PN 40 / 600 for DN100 / 5" and higher extended temperature range from -20 °C to +180 °C / -4 °F to 356 °F sensor protection class IP 68
approval MID	TCM 142/16-5353

\*) optional measurement accuracy  $\pm 1\%$  for velocity of the measured liquid  $v > 0.5 \text{ m/s} / 1.64 \text{ ft/s}$

#### FLOW METER SENSOR

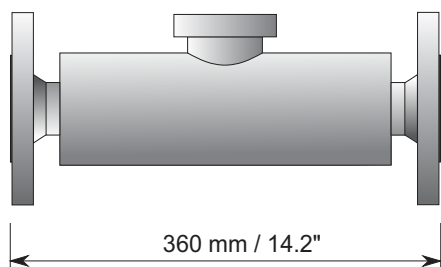

#### ELECTRONIC UNIT

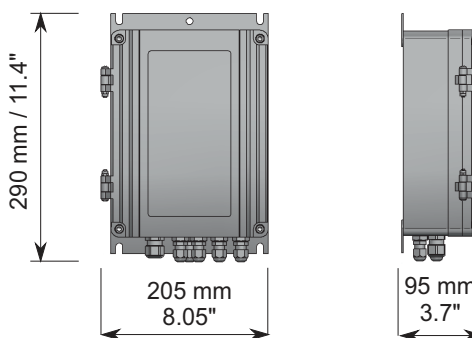

ELIS PLZEŇ a. s.  
LUCNI 425/15, 301 00 PLZEN  
CZECH REPUBLIC

Phone: +420 377 517 711  
FAX: +420 377 517 722  
e-mail: [sales@elis.cz](mailto:sales@elis.cz)  
<http://www.elis.cz>